

Sunnex OSM

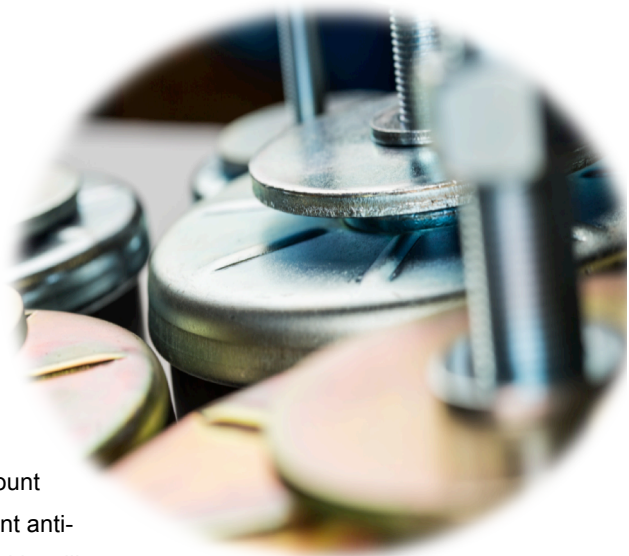
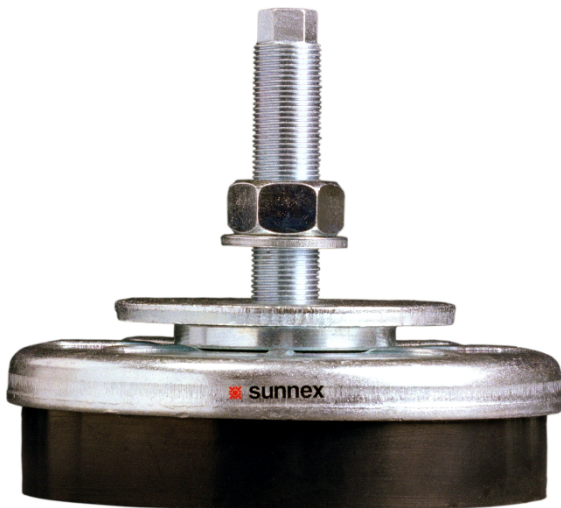

Sunnex OSM is the original machine mount with excellent anti-vibration and levelling

performance. Designed for a versatile and professional use within industrial and production applications. Proven quality and effective vibration damping with great noise reduction properties.

Sunnex OSM consists of a fine threaded pressure plate adjusted by an integrated levelling bolt. The design rests on a steel chassis with a rubber damping mixture that is highly resistant to grease, oil and cooling emulsions.

With a Swedish manufacturing legacy, dating back to the 1960's, Sunnex OSM is the original machine mount built with an authentic quality for long-term cost efficiency.

Preferences

- Loads up to 5500 kg, per machine mount
- Galvanized
- Special Nitrile rubber mixture
- Integrated bolt with precision levelling
- Pressure plate for shock absorption

Applications

- Manufacturing industry
- Process industry
- Press- & stamping machines
- Extrusion machines
- Light to heavy duty machines

Advantages

- Excellent anti-vibration
- Excellent levelling
- Excellent friction to surface
- Reduction of noise

Technical specification OSM

Rubber:	Special Nitrile rubber mixture
Finish:	Galvanized
Load capacity:	50-5500 kg
Diameter, D:	80-200 mm
Height, H:	38-71 mm
Bolt Length:	120-170 mm
Key grip 1, NV1:	9-15 mm
Key grip 2, NV2:	19-30 mm

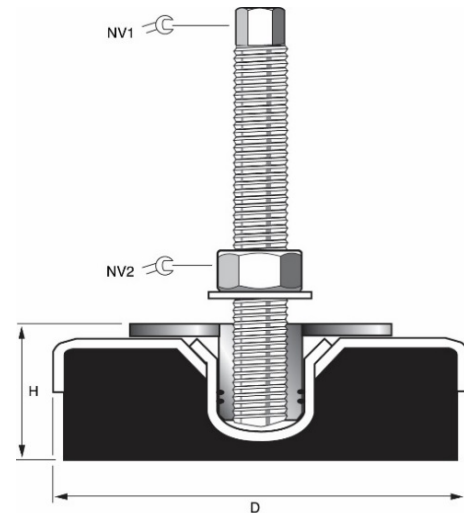

Model	Load area daN (kg)	Injection moulds <100 cycles/h daN (kg)	Presses, strokes/min			Levelling bolt	NV1 mm	NV2 mm	D mm	H mm	Part no.
			<125 daN (kg)	125-160 daN (kg)	160-200 daN (kg)						
OSM 1	50-500	50-200	70-200	60-140	50-120	M12x1,25x120	9	19	80	38-50	10331
OSM 2	400-1000	200-400	200-400	120-350	100-250	M16x1,50x120	12	24	120	46-59	10332
OSM 3	800-2000	400-1000	400-1400	350-1100	250-725	M20x1,50x170	15	30	160	53-68	10333
OSM 4	1500-4000	1500-2500	1700-2800	1000-2100	800-1400	M20x1,50x170	15	30	160	54-69	10334
OSM 5	3000-5500	2000-3800	3000-4000	2000-3500	1400-2400	M20x1,50x170	15	30	200	56-71	10335