

Sunnex LLM19



Sunnex LLM19 is a levelling machine mount. This mount is specially designed for stable levelling of lighter equipment

All machine mounts in the LLM19 series consists of a levelling bolt with a vulcanized rubber feet, in two different degrees.(IRH)

The rubber molding has excellent friction to the surface and provides a safe and dependable installation.

Preferences

- Loads up to 75 kg per machine mount
- Galvanized or stainless steel
- Special Nitrile rubber mixture
- Integrated vulcanized bolt with precision levelling.

Applications

- Small machines
- Assembly stations
- Office equipment
- Home appliances
- Compressors

Advantages

- Excellent levelling
- Excellent friction to surface
- Excellent anti-vibration
- Reduction of noise

Technical specification LLM19

Rubber:	Special Nitrile rubber mixture
Finish:	Stainless or galvanized steel
Load capacity:	Up to 75 kg
Diameter, D:	46 mm
Height, H:	53-75 mm
Length, L:	38-60 mm
Key grip, B:	17 mm
Bolt size, A:	M10

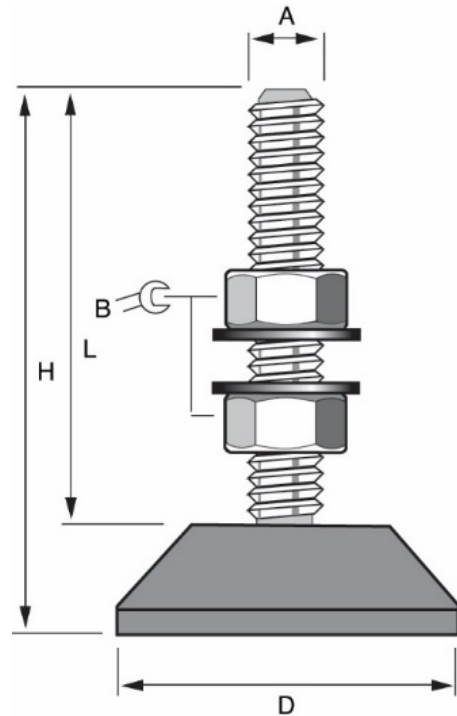

Model	Max load per machine mount daN (kg)	D mm	A mm	B mm	H mm	L mm	Stainless / Galvanized	Color	Part no.
LLM 19	40	46	M10	17	53	38	G	Grey	10405
							S	Grey	10406
					75	60	G	Grey	10409
							S	Grey	10404
	75	46	M10	17	53	38	G	Black	10400
							S	Black	10401
					75	60	G	Black	10407
							S	Black	10408